

XGE High Performance Ethernet

XGE4120-CCXMC-RC-G Data Sheet: Dual Port 10 Gb Ethernet CCXMC (rear XAUI/KX4)

XGE4120 CCXMC Conduction Cooled

The XGE4120-CCXMC provides 10 Gb Ethernet (10GbE) connectivity for embedded systems with the ultra-high performance characteristics that are essential for data intensive real-time systems. It provides high performance RDMA and Streaming protocol in addition to 100% compatibility and interoperability with all industry standard Ethernet infrastructures and protocols.

The XGE4120-CCXMC provides a dual port 10 GbE TOE CCXMC with a PCIe x8 host interface. The XGE4120 offloads TCP/IP, RDMA, and UDP Direct Stream protocols to dedicated silicon protocol engines with each port capable of 2500 MB/s (2.5 GB/s) of sustained throughput.

XGE Hardware Offload Advantage

Ethernet interfaces can stifle the performance of even the most powerful embedded CPUs when trying to move data at high rates at full wire speed. This is due to the significant overhead caused by the TCP/IP protocol stack (i.e. “software stack”) in traditional Ethernet implementations. This problem gets many times worse when attempting to leverage the performance of 10 GbE. The XGE series offloads most of the network protocol processing to dedicated silicon protocol engines and frees the I/O protocol processing from the host CPU. The XGE product family differentiates itself from typical Ethernet NICs by delivering high sustained throughput, maximum host processor offload, ultra-low latency, and solid deterministic behavior.

UDP Direct Stream Support

UDP Direct Streaming send/receive allows extremely efficient large sends and receives of UDP data directly from application level buffers, completely avoiding the standard O/S network stack and associated data copies. The application send/receive buffers may be located in host CPU memory, or in any other PCIe addressable memory, such as the memories attached to PCIe connected Graphic Processing Units (GPUs). UDP Direct Streaming is fully compatible with standard UDP.

RDMA Support

When used in conjunction with a Data Center Ethernet (DCE) switches, XGE Interfaces supports the Ethernet Remote Direct Memory Access (RDMA) protocol. RDMA allows data movement directly between application memories without any CPU involvement. RDMA provides a mechanism for extremely efficient data transfer with ultra-low microsecond level board to board latencies on DCE enabled Ethernet networks.



XGE4120-CCXMC-RC-G Features:

- Dual Port 10 GbE interface
- CCXMC with PCIe x8 host interface
- Simultaneous line rate throughput on both ports
- UDP direct streaming support
- RDMA support (with DCE enabled switches)
- 100% standard Ethernet compatibility
- Standard Sockets programming interface
- Highly efficient large send/receive offload
- Very low host processor overhead
- Ultra low latency and high determinism
- Zero Copy / Direct Data Placement (into app memory)
- Very low power consumption
- Air and rugged conduction cooled versions available
- Software drivers for Linux, VxWorks, and Windows

Extensive Software Support & Capability

Critical I/O supplies all the hardware, drivers, libraries, and protocol support you'll need for rapid system development without wasting your time debugging drivers. All software has been highly optimized to deliver maximum performance, reliability, and capability.

The XGE4120 hardware is accompanied by an extensive offering of software libraries and device drivers with support for a multitude of embedded / real-time operating systems as well as mainstream OS platforms (VxWorks, Linux, and Windows).

Compatibility

The XGE interface provides 100% standard 10 Gb Ethernet connectivity. The XGE sockets interface model maintains full compatibility with all applications, including both custom user applications as well as “pre-built” network applications such as NFS, FTP, Telnet, etc..

XGE4120 CCXMC (rear XAUI/KX4 I/O) Technical Specifications

Controller Architecture	Hardware protocol offload processor
Ethernet Rates	10 Gbps/port
Data Transfer Rate	2500 MB/s (2.5 GB/s) (per port, full-duplex)
Topology	Switched & point to point
Protocol Support	TCP, UDP, IP, UDP Direct Streaming, RDMA, all other standard network protocols
Host Bus Interface	PCI-Express x8 (x8, x4, x2, x1 supported), PCIe 2.0 (1.1 compatible), 5GT/s or 2.5GT/s
Ports	Two XAUI/KX4 copper ports
Connectors	XAUI/KX4 vi XMCconnectors
Form Factor	Conduction Cooled XMC, VITA 42.0, VITA 42.3, VITA 20-2001 (R2005) VITA 61 XMC2 connectors available
Power Requirements	+5VDC at 2A (max) or +12VDC at 1A (max)
Power Consumption	5.0 Watts (typical)
Temperature	Operating: -40C to +85C; Storage: -50C to +125C
Humidity	0-95% non condensing
Supported Host Processors	Intel, PowerPC
Vibration (random)	VITA 47 Class V3: 0.1g2/Hz (14.1 grms) 15-2000 Hz
Shock	VITA 47 Class OS2 40g Peak sawtooth (11ms duration)
Software Support	Drivers: VxWorks, Linux, Windows (protocol support varies by OS, contact Critical I/O)
Model Number	XGE4120-CCXMC-RC-G (VITA 42 XMC connectors) XGE4120-CCXMC6-RC-G (VITA 61 XMC2 connectors)
Model Description	Dual ported 10 Gigabit Ethernet TOE XMC, rear XAUI/KX4, commercial temp, air-cooled hardware, RoHS LEAD FREE assembly

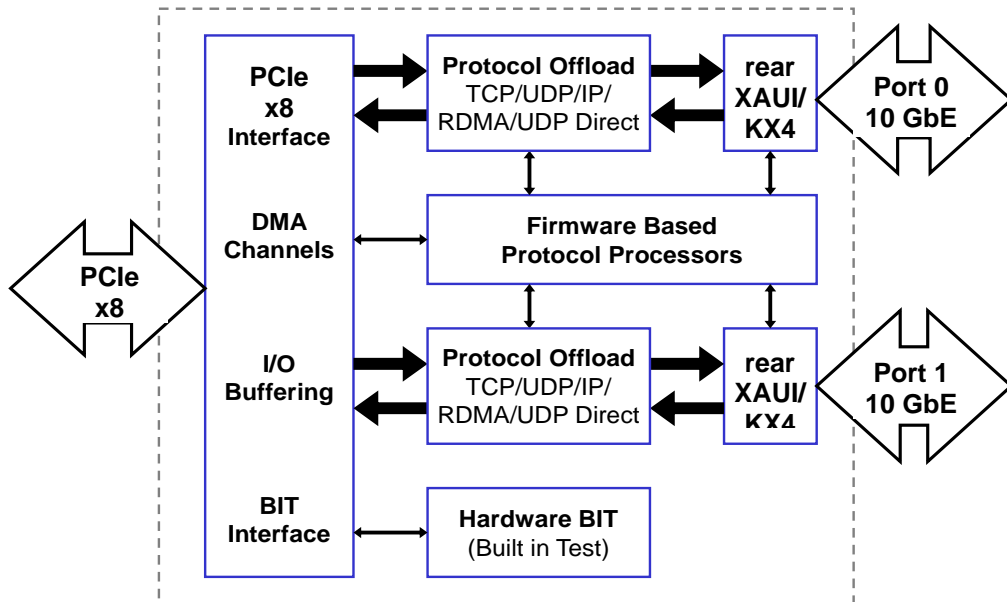

Block Diagram: Functional block diagram for the XGE4120 CCXMC by Critical I/O. This CCXMC provides two independent 10 Gb Ethernet ports, each with integrated protocol offload hardware. Dedicated hardware offload provides full duplex operation at wire-speed, up to 2500 MB/s (2.5 GB/s) (per port).